

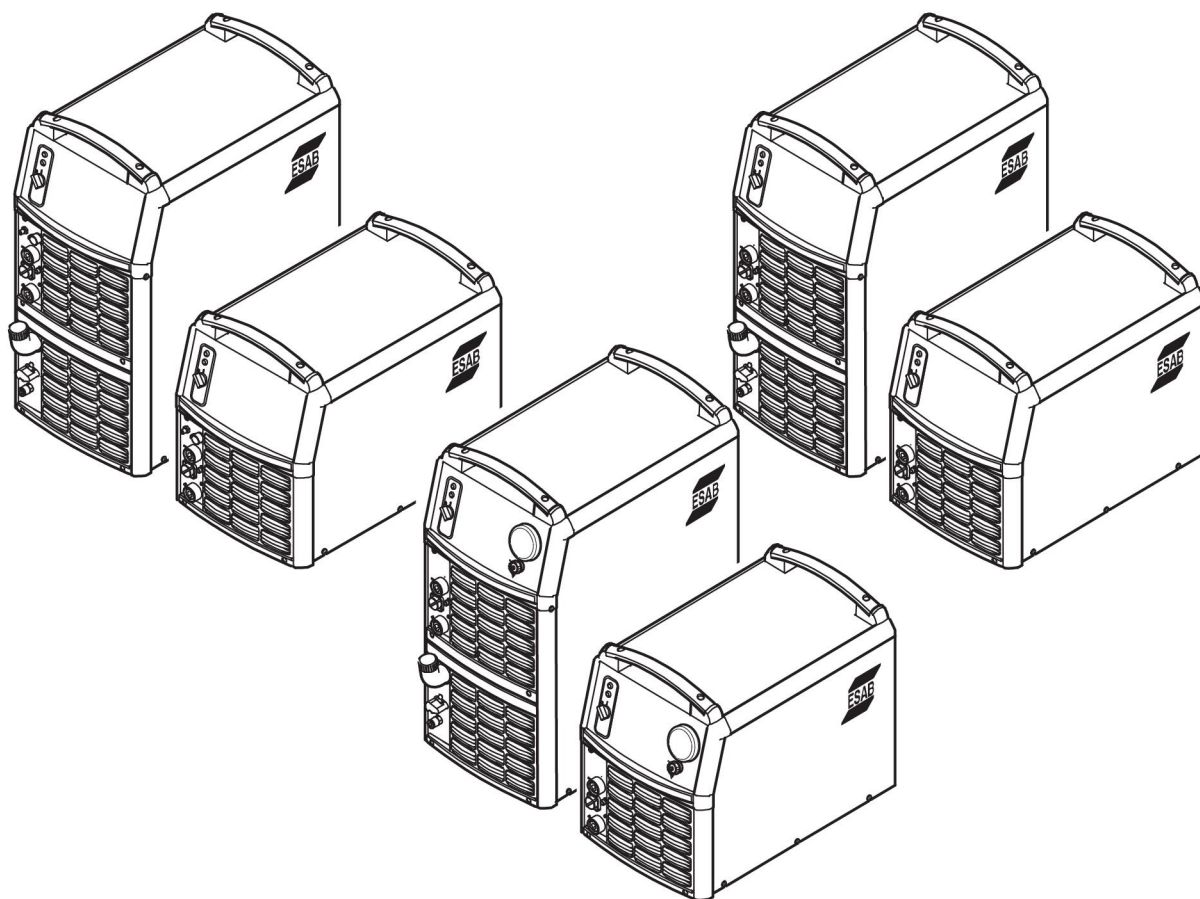

Aristo®

***Mig 5000i, Mig U5000i,
Mig 5000i WeldCloud™,
Mig U5000i WeldCloud™
460 V***



Spare parts list

Ordering no.	Product	Serial no.	Notes
0459 230 884	Mig 5000i	803-, 945-, 950-xxx-xxxx	460 V
0459 230 885	Mig U5000i	803-, 950-xxx-xxxx	460 V
0459 230 886	Mig U5000iw	803-, 950-xxx-xxxx	460 V with cooling unit
0445 400 884	Mig 5000i WeldCloud™	608-, 613-, 834-xxx-xxxx	460 with WeldCloud™ unit
0445 400 885	Mig U5000i WeldCloud™	608-, 613-, 834-xxx-xxxx	With WeldCloud™ unit
0445 400 886	Mig U5000iw WeldCloud™	608-, 613-, 834-xxx-xxxx	With cooling unit and WeldCloud™ unit

Spare parts may be ordered through your nearest ESAB dealer, see esab.com. When ordering, please state product type, serial number, denominations and ordering numbers according to the spare parts list. This facilitates dispatch and ensures correct delivery.

Maintenance and repair work should be performed by an experienced person, and electrical work only by a trained electrician. Use only recommended spare parts.

SPARE PARTS LIST	4
Mig 5000i, Mig U5000i 460 V	4
Mig 5000i 460 V	6
Mig U5000i 460 V	7
Mig 5000i, Mig U5000i 460 V	9
Mig 5000i, Mig U5000i 460V	12
Mig U5000i 460 V	15
Mig 5000i, Mig U5000i 460 V	17
Mig 5000i, Mig U5000i 460 V	20
Mig U5000i WeldCloud™, Mig 5000i WeldCloud™ 460 V	21
Spare parts sets	27

SPARE PARTS LIST

Mig 5000i, Mig U5000i 460 V

Item	Qty	Ordering no.	Denomination	Notes
BA1	4		Screw	High tensile steel, included in item BA2
BA2	2	0459 307 881	Handle set	
-	2		Nut	M8, included in item BA2
BA3	4		Handle corner	Included in item BA2
BA4	1	0458 399 002	Rubber mat	
BA5	1	0458 390 005	Cover	
BA6	4	0458 310 001	Gasket	Seal
BA7	1	0468 516 887	Mains cable	
BA8	1	0469 950 880	Cable clamp	
-	3		Screw	RXPT 8-16x20
BA9	1	0459 121 881	Rear plate middle size	Rear panel, medium
BA10	1	0192 526 002	Sealing strip	To be ordered per meter
BA11	1	0458 387 002	Side cover middle	Side panel, medium, right
BA12	1	0458 388 002	Side cover middle	Side panel, medium, left
BA13	1	0458 385 001	Bottom plate	
BA14	4	0458 683 001	Foot	
-	4		Screw	M6x19
BA15	1	0458 390 003	Front profile middle size	Front panel, medium
BA16	1	0458 396 001	Front frame	
BA17	5	0469 381 001	Fast lock nut	
BA18	1	0458 623 004	Connection plate, cooler	
BA19		0458 398 001	Filter	
BA20		0458 383 001	Front grille	
BA21	1	0458 511 001	Middle beam	Bracket
BA22	1	0458 509 001	Lower beam	Bracket
-	2		Screw	M6x20
BA23	1	0459 121 880	Rear plate low	Rear panel, short
-			Screw	M6x16
BA24	1	0458 387 001	Side cover low	Side panel, short, right
-			Screw	M6x16
BA25	1	0458 390 002	Front profile low	Front panel, short
-			Screw	M6x16
-			Washer	Ø 11/6.4x2.1
BA26	1	0458 388 001	Side cover low	Side panel, short, left

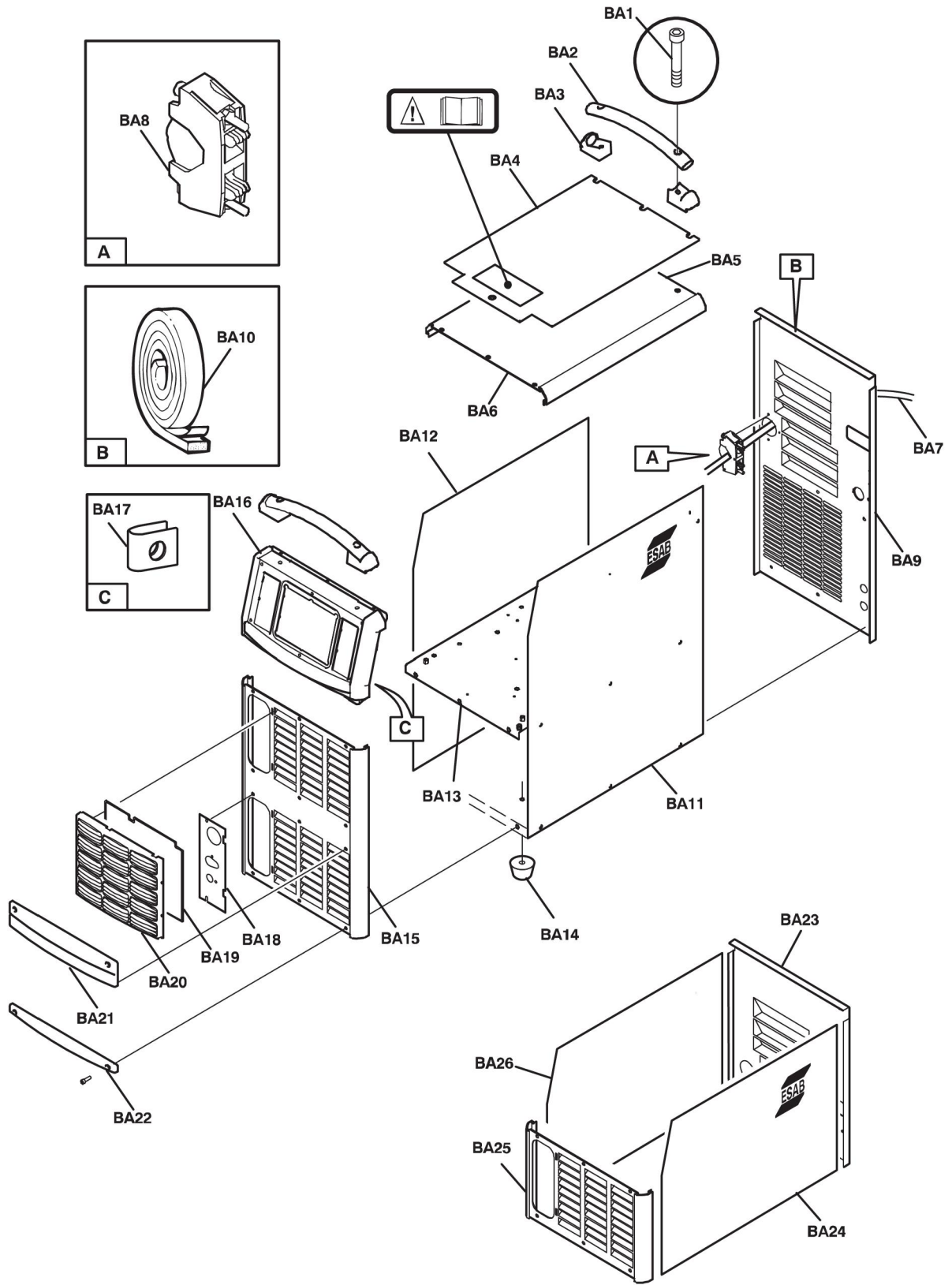

Mig 5000i 460 V

C = Component designation in the circuit diagram					
Item	Qty	Ordering no.	Denomination	Notes	C
AB1	1	0458 623 001	Connection plate		
AB2	1	0366 285 001	Cap		
AB3	2	0160 362 881	Cable connector	OKC	XS1, XS2
AB4	2	0466 325 001	Gasket		
AB5	1	0458 681 883	Cable	Connectors included	XP1, XS3
AB6	1	0456 686 880	Clamp		
AB7	1	0368 544 003	Socket	12 pole	XS3
-	3		Screw	RXPT 6-19x8	
AB8	1	457 799 001	Screen plate		
AB9	1	0467 911 883	Capacitor		C3
AB10	1	0458 969 001	Insulation		
-	4		Screw	MRX M4x12	
AB11	4	0194 142 412	Nut	M4 domed, plastic	

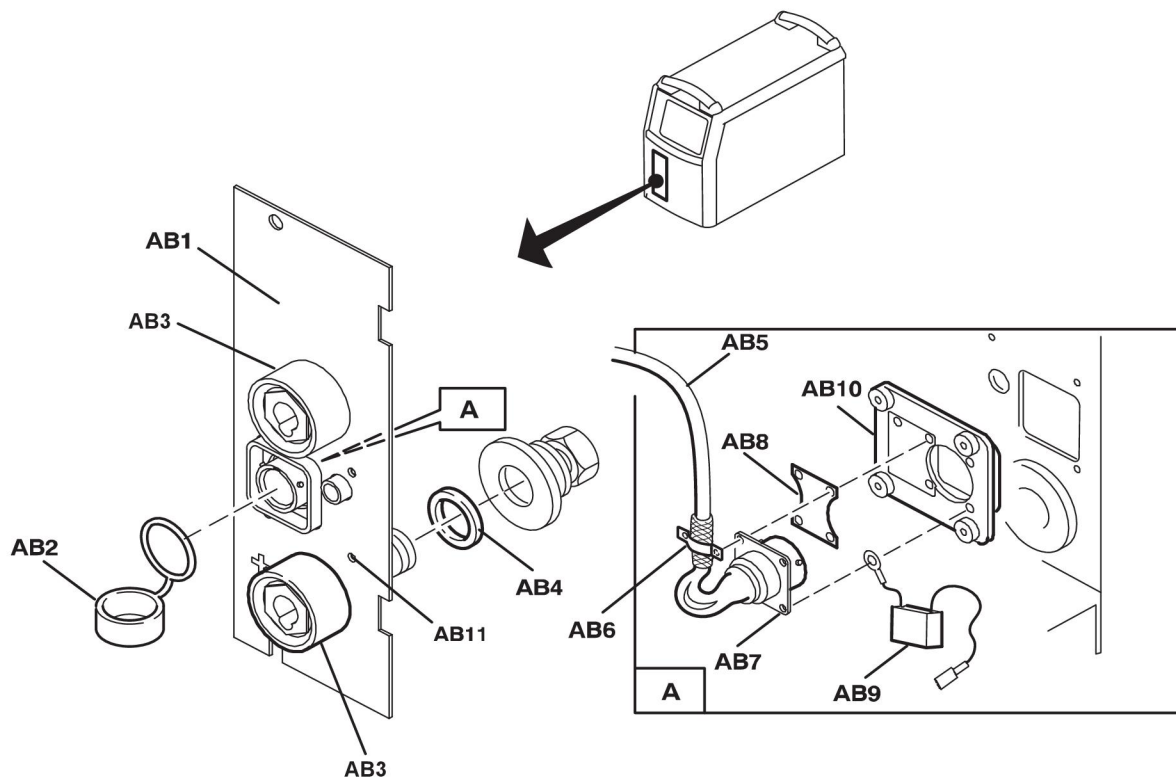

Mig U5000i 460 V

C = Component designation in the circuit diagram					
Item	Qty	Ordering no.	Denomination	Notes	C
DB1	1	0192 713 001	Hose nipple		
DB2	1	0538 500 902	Sleeve terminal	2 pole	XS4
-	4		Screw	RXPT 6-19x8	
DB3	1	0458 879 001	Inlet plug		
DB4	1	0458 623 002	Connection plate		
DB5	1		Nut	M12	
DB6	1	0457 626 001	Cap		
DB7	1	0366 285 001	Cap		
DB8	1	0160 362 881	Cable connector	OKC	XS1
DB9	2	0466 325 001	Gasket		
DB10	4	0194 142 412	Nut	M4 domed, plastic	
DB11	1	0156 868 880	Welding cable connector	OKC	XS2
DB12	1	0458 681 883	Cable single		XP1, XS3
DB13	1	0456 686 880	Clamp		
DB14	1	0368 544 003	Socket	12 pole	XS3
-	3		Screw	RXPT 6-19x8	
DB15	1	0467 911 883	Capacitor	100 nF 250 V, with cable lugs	C3
DB16	1	457 799 001	Screen plate		
DB17	1	0458 969 001	Insulation		
-	4		Screw	MRX M4x12	

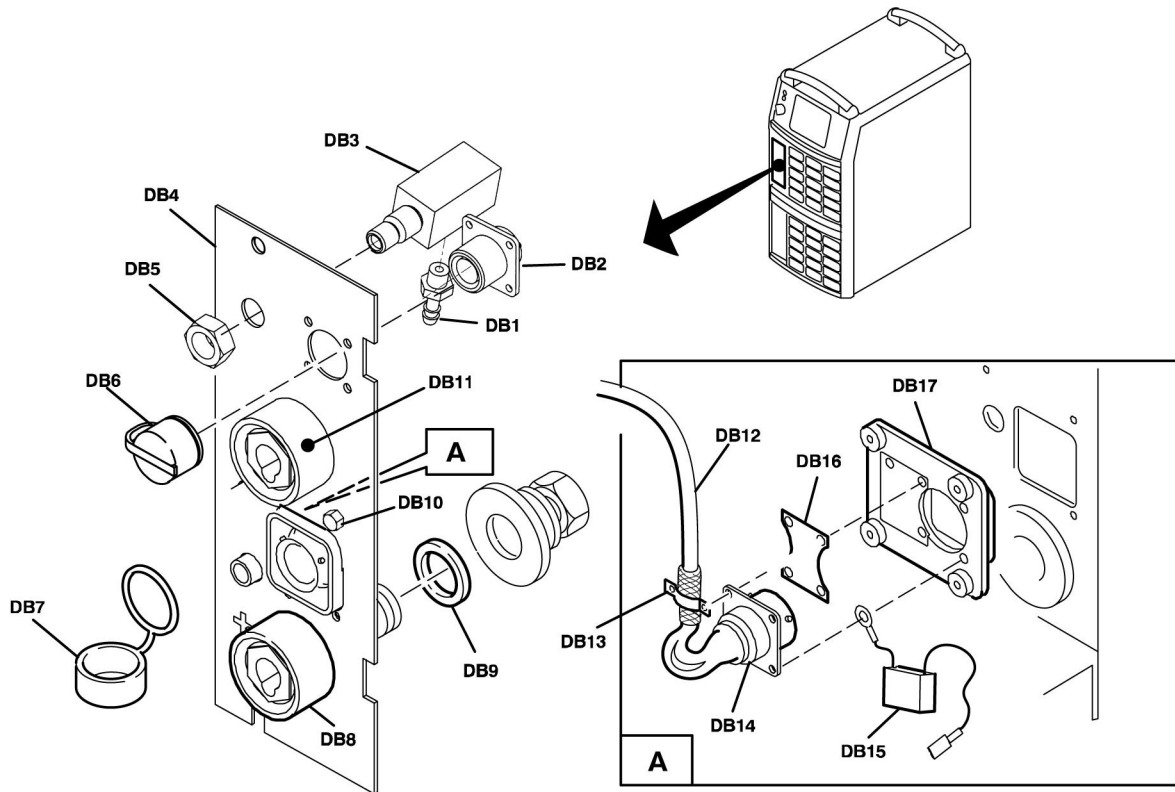

Mig 5000i, Mig U5000i 460 V

C = Component designation in the circuit diagram					
Item	Qty	Ordering no.	Denomination	Notes	C
BC1a	1	0458 312 001	Top box		
BC1b	1	0487 201 850	Circuit board	Configured for equipment ID 17 Replacing 0487 201 888	20AP1
BC1c	1	0458 313 001	Bottom box		
-	2		Screw	M5x8	
-	2		Screw	RXPT 8-16x12	
BC2	1	0458 881 001	Protection cap		
BC3	1	0458 681 884	Cable double burndy	Included in item BC18	XP2, XS30
BC4	2	0193 052 980	Screw		
BC5	1	0458 629 884	Cable set common	Connectors included: XP6, XS7, XS8, XS15, XS20, XS21, XS22, XS23, XS24, XS25, XS27, XS28	<-----
BC6	1	0458 314 001	Dust protection		
BC7	1	0394 516 038	Spacer screw	M5x30	
BC8	1	0486 855 884	Printed circuit board	Relay board, Replacing 0486 855 880	20AP2
-	1		Screw	M5x8	
-	1	0193 700 704	Ribbon cable	Included in item BC8. Connecting 20AP2 to 20AP1	20XS1
BC9	9		Connector	Included in item BC5	
BC10	1	0466 884 003	Connection		XP6
BC11	2		Socket	Included in item BC5	
BC13	1	0459 285 001	Fuse	4 AT	
BC14	1	0459 284 001	Fuse holder		
BC15	1	0456 806 001	Cover plate		
BC16	1	0458 709 002	Cover 2-hole	For Mig 5000i	
BC16	1	0458 709 003	Cover 3-hole	For Mig U5000i	
BC17	1	0458 629 885	Cable set	Connectors included: XS10, XS11, XS16, XS17, XS18, XS26, XS29, XS31	<-----
BC18	1	0458 679 881	Operating contact CAN doub.	Items BC3, BC18a, BC18b, BC18c, BC18d and BC18e included	AP1, C4
BC18a	1	0486 388 880	Circuit board	Connection board	AP1
BC19	2	0366 285 001	Dust cap		
BC20	1	0459 314 880	Terminal resistor	Termination resistor	
BC21	1	0192 230 105	Blind plug	Only for Mig 5000i	
BC22	1	0192 038 102	Flat pin connector	5.3 mm	

SPARE PARTS LIST

C = Component designation in the circuit diagram					
Item	Qty	Ordering no.	Denomination	Notes	C
BC23	1	0459 147 882	Cable set coarse		
BC24	3	0194 069 003	Rubber inlet	Grommet	
BC25	2	0458 074 001	Inlet		
BC26	2	0191 548 009	Flat pin connector	Ø 6.3x0.8	
BC27	1	0458 624 003	Connection rail		
-	2		Washer	Ø 22/10.5x2	
-	2		Screw	M10x16	
-	2		Screw	M8x16	
-	2		Nut	M8	
BC28	1	0459 125 001	Connection rail	For Mig 5000i	
BC28	1		Connection rail	See item DD12 and DD13 for Mig U5000i	
BC29	1		Power module	See items AE1 to AE49	
-	6		Screw	M6x16	
BC30	1	0486 892 882	Printed circuit board		
BC31	1		Mains module	See items BD1 to BD22	
-	6		Screw	M6x16	
BC32	1	0458 802 003	Front panel		
-	3		Washer	Ø 4.3X8	
-	7		Nut	M4	
BC33	1	0369 733 005	Lamp	Orange LED	D1
BC34	1	0369 733 010	Indicating lamp	White	HL1
BC35	1	0458 601 001	Switch		2QF1
-	2		Screw	FXS ST3.5x9.5	
BC36	1	0366 296 003	Knob		

SPARE PARTS LIST

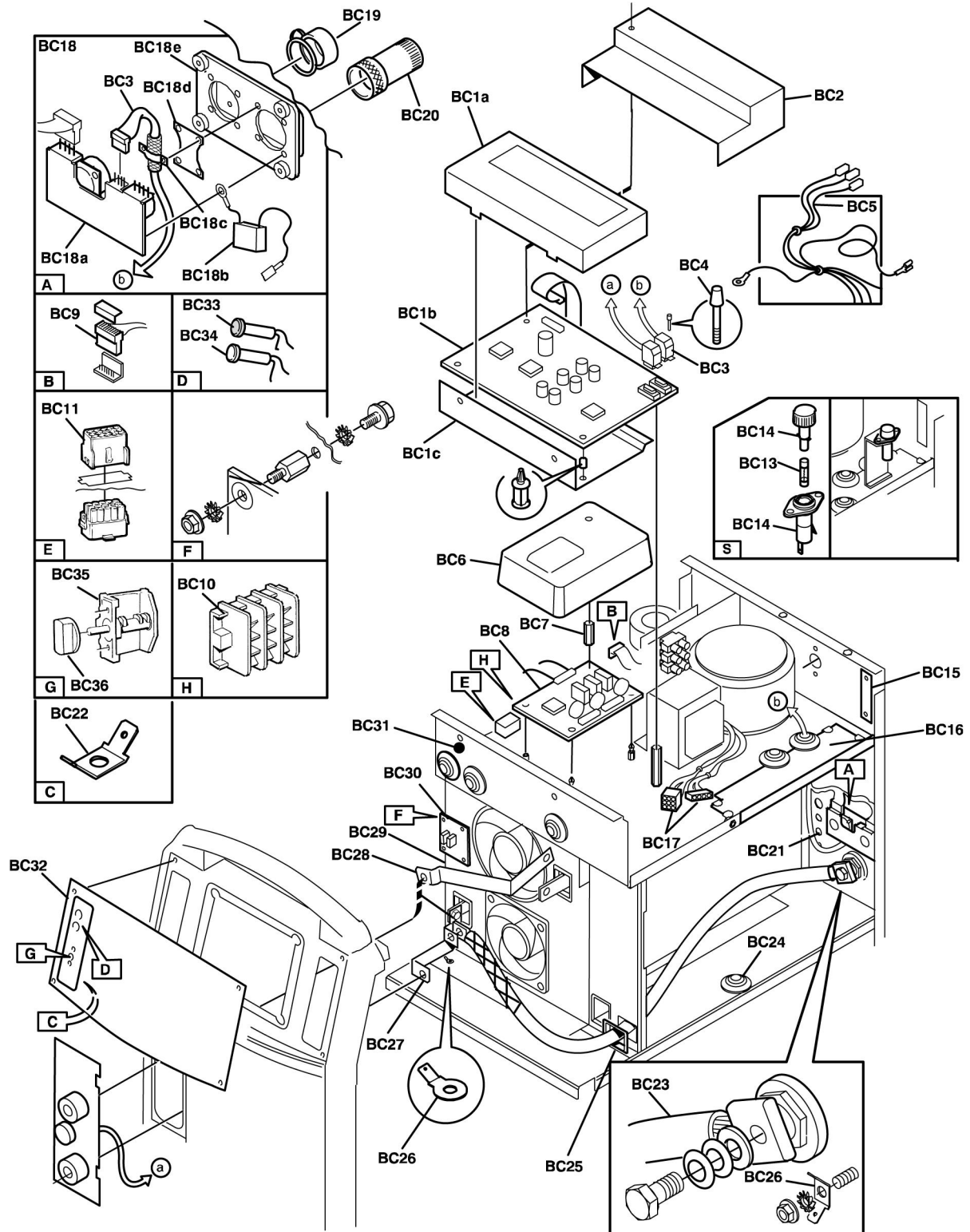

Mig 5000i, Mig U5000i 460V

C = Component designation in the circuit diagram					
Item	Qty	Ordering no.	Denomination	Notes	C
BD1	1	0458 392 001	Circuit board shelf		
BD2	1	0193 350 101	Grommet strip	L = 30 mm. To be ordered per meter	
BD3	1	0394 516 033	Distance screw	Spacer screw M5x12	
BD3	3	0394 516 033	Distance screw	Spacer screw M5x12. From ser. no. 950-xxx-xxxx	
-	2	0394 516 044	Distance screw	Spacer screw M5x60	
-	4	0394 516 044	Distance screw	Spacer screw M5x60. From ser. no. 950-xxx-xxxx	
-	2		Washer	Ø 10/5.3	
-	2		Screw	M5x8	
BD4	3	0192 790 104	Spacer	12.7 mm	
BD5	2	0194 019 005	Spacer	6.4 mm	
BD6	1	0193 502 105	Contactor	400 V	2KM1
BD7	1	0193 298 101	Bar for contactor		
-	2		Screw	M5x8	
BD8	1	0458 607 001	Control transformer	With fuses 2FU2, 2FU3 and 2FU6	2TC1
-	2		Screw	M6x16	
BD9	1	0458 878 001	Sign		
BD10	1	0193 655 012	Terminal block	Delivered as 12 pole, to be cut to 6 pole	2XT2
-	2		Screw	RXS B8x19	
BD11	1	0459 124 001	Transformer		2TC3
BD12	1	0320 378 011	Mains select block	Terminal block Delivered as 12 pole, to be cut to 3 pole	2XT1
-	2		Screw	M4x25	
BD13	1	0468 882 004	Sign		
BD14	1	0264 300 404	Washer	KB6.5	
BD15	1		Washer	Ø 16/8.4x1.5	
BD16	2	0219 501 309	Washer lock AZ	Ø 11/6.4x2.1	
BD17	2		Screw	M6x16	
BD18	1	0458 611 882	Cable set mains module	Connectors included	2XS1, 2XS2, 2XT2
BD19	1	0458 608 001	Auxiliary transformer	Up to and including ser. no. 803-903-5788 Fuses 2FU4 & 2FU5 included	2TC2
	1	0458 608 880	Auxiliary transformer	From ser. no. 803-903-5789 Fuses 2FU4 & 2FU5 included	2TC2

SPARE PARTS LIST

C = Component designation in the circuit diagram					
Item	Qty	Ordering no.	Denomination	Notes	C
-	1	0567 900 151	Fuse 8 A slow	Up to and including ser. no. 803-903-5788	2FU4
BD20	1	0193 586 102	Fuse (MCB) 10 A slow	From ser. no. 803-903-5789	2FU4
BD21	1	0455 376 001	Protection cap for 2FU4	From ser. no. 803-903-5789	
-	1	-	Fuse 2 A slow		2FU5
-	1		Screw	M8x110	
-	1		Nut	M8	
BD22	1	0455 803 881	Circuit board	From ser. no. 950-xxx-xxxx	2AP1

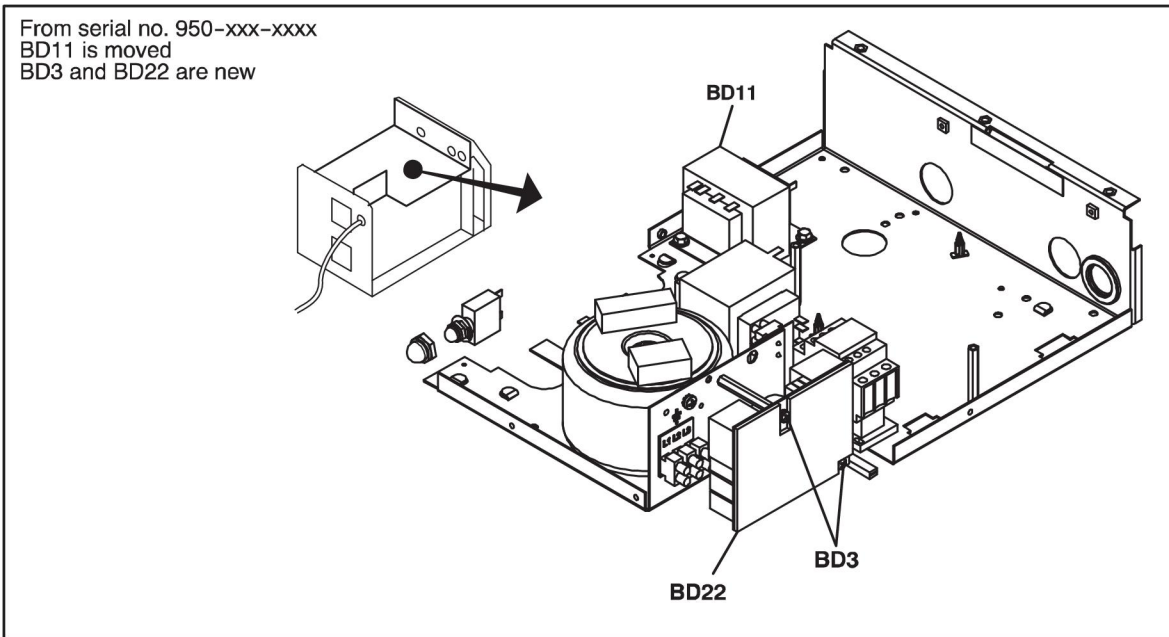
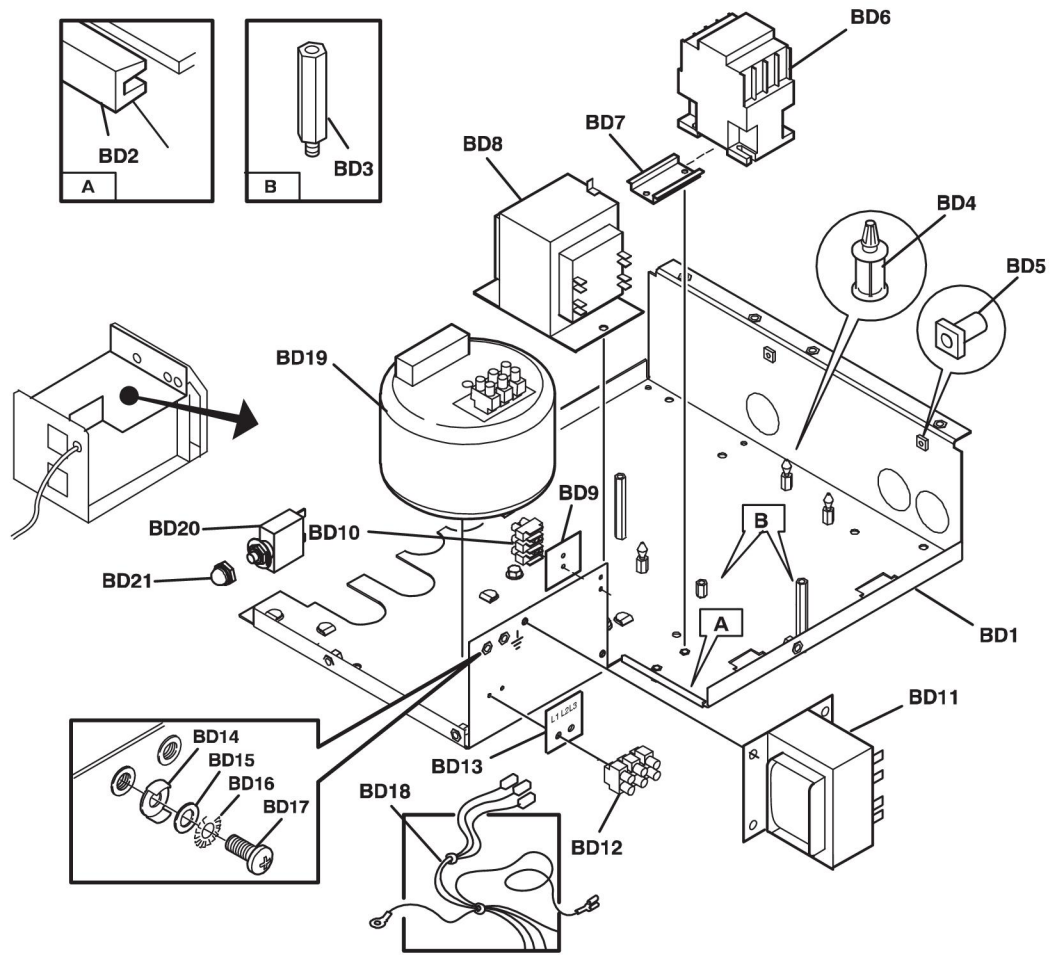

Mig U5000i 460 V

C = Component designation in the circuit diagram					
Item	Qty	Ordering no.	Denomination	Notes	C
DD1	1	0367 268 001	HF module	Included in item DD11	10AP1
DD2	1		Capacitor	47 nF 250 V	10C1
DD3	1	0459 272 880	Solenoid valve complete	42 V AC	10YV1
-	2		Screw	M4x6, Included in item DD3	
-	1		Nipple	Included in item DD3	
DD4	1		Gas valve bracket	Included in item DD3	
DD5	1		Spacer washer	Included in item DD3	
DD6	3	0194 019 005	Spacer	6.4 mm	
-	3		Screw	RX PT 8-16x12	
DD7	1	0456 496 001	Hose	Red, L = 0.97 m, to be ordered per meter	
DD8	1	0459 086 001	Bracket		
DD9	1	0192 041 119	Grommet		
DD10	2	0458 074 001	Inlet		
DD11	1	0467 756 882	HF coils complete		10TV1
-	2		Screw	M6x19	
DD12	1	0459 125 002	Connection rail		
DD13	1	0459 077 003	Connection rail		

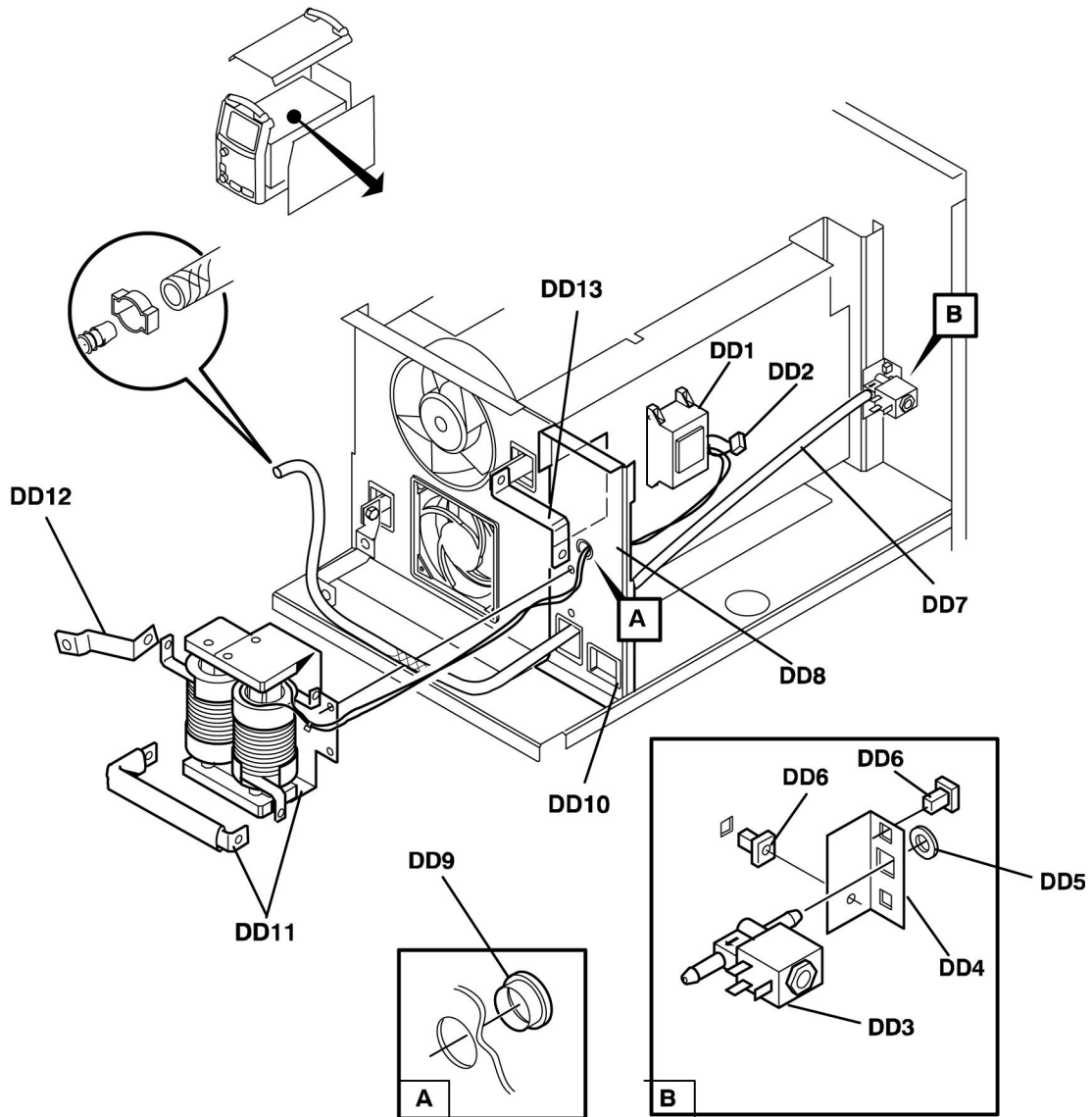

Mig 5000i, Mig U5000i 460 V

C = Component designation in the circuit diagram					
Item	Qty	Ordering no.	Denomination	Notes	C
AE1	1	0459 075 880	Inductor		15L3
-	1		Screw	M6SF-TT, M6x14	
-	1		Screw	M5x10	
AE2	9	0458 074 001	Inlet	Grommet	
AE3	1	0458 064 882	Cable set 500	Connectors included: 5XP7, 15XP8, 15XS4, 15XS9	<-----
AE4	1	0458 067 002	Rail		
AE5	1	0459 081 002	Rail		
AE6	1	0459 081 004	Rail		
-	2		Screw	M8x25	
-	2		Screw	M8x16	
-	4		Nut	M8	
AE7	1	0459 081 001	Rail		
AE8	1	0459 081 003	Rail rear		
AE9	8	0455 569 001	Ferrit ring core	15L1, 15L2, 15L4, 15L5	<-----
-	4	0040 953 611	Cable tie	Heat resistant	
AE10	1	0459 051 880	Current sensor		15AP3
AE11	1	0191 548 009	Flat pin	6.3x0.8	
AE12	1	0486 979 880	Filter board		15AP4
AE13	7	0467 212 002	Spacer screw		
AE14	1	0192 041 129	Grommet		
AE15	1	0460 118 001	Primary inductor		3L1
AE16	1	0459 082 001	Mounting plate		
AE17	1	0194 069 002	Rubber inlet	Grommet	
AE18	1		Semiconductor module	See items AF1-AF8	
AE19	1	0459 079 002	Intermediate plate		
AE20	2	0458 075 882	Transformer module		15TM1, 15TM1
-	6		Screw	M6SF-TT M6x14	
AE21	2	0458 076 001	Fan attachment		
AE22	4	0192 903 505	Capacitor	1000 µF, 450 V	
AE23	4	0320 901 003	Insulating nut	M12	
AE24	1	0458 058 001	Support plate		
-	2		Screw	M6SF-TT, M5x10	
AE25	1	0459 271 001	Air guide		
AE26	1	0192 041 119	Grommet		
AE27	4	0190 209 120	Hose	Ø 15.9/14, L = 45 mm, to be ordered per meter	

C = Component designation in the circuit diagram					
Item	Qty	Ordering no.	Denomination	Notes	C
AE28	1	0458 064 883	Cable set gate	Connectors included: 15XS3, 15XS5, 15XS6, 15XS7, 15XS8, 15XS11	<-----
AE29	3	0458 991 001	Spacer screw	M5x27	
AE30	13		Nut	M5	
AE31	16	0219 504 302	Spring washer	Ø 10/5.2x0.5	
AE32	8		Washer	Ø 16/5x1	
AE33	4	0458 991 003	Spacer screw	M5x10	
AE34	2	0459 109 001	Insulation		
AE35	8	0194 143 327	Screw	M5x12 See * below	
AE36	1	0486 983 880	Circuit board	Note: Read the service manual	15AP1
AE37	24	0194 143 368	Screw	M6x16 See * below	
AE38	1	0458 064 884	Cable set driver board		
AE39	1	0486 975 882	Circuit board		15AP2
AE41	2	0192 790 106	Spacer		
AE42	1	0458 055 001	Spacer		
AE43	1	0459 128 001	Fan		15EV2
-	2		Screw	MRX-TT M4x8	
AE44	1	0459 127 001	Fan		15EV1
AE45	1	0459 078 002	Fan plate		
-	3		Screw	M6SF-TT M6x19	
AE46	1	0459 077 002	Rail		
AE47	1	0459 236 001	Insulation		
AE48	1	0459 077 004	Rail		
AE49	2	0193 350 101	Grommet strip	L = 95 mm	

* Special screw with built-in washer and spring washer function

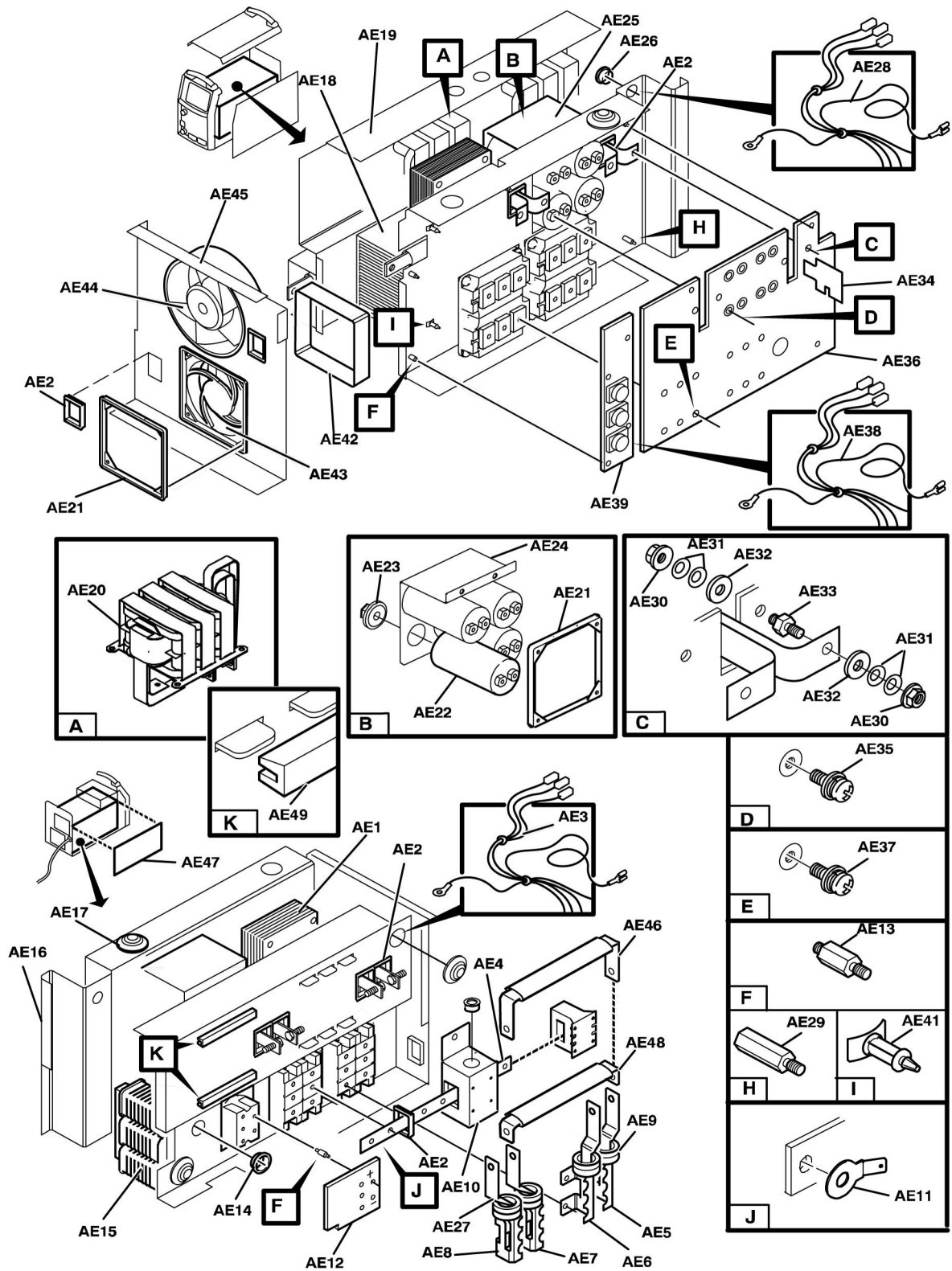

Mig 5000i, Mig U5000i 460 V

C = Component designation in the circuit diagram					
Item	Qty	Ordering no.	Denomination	Notes	C
-	1	0458 073 881	Semiconductor module	Complete. Items AF1-AF8	
AF1	2	0194 143 329	Screw	M5x16 See * below	
AF2	24	0194 143 370	Screw	M6x20 See * below	
AF3	1	0301 011 007	Heat sink		
AF4	1	0456 113 888	Thermal switch		15ST2
AF5	1		Rectifier bridge	See item AF51	15BR1
AF6	4		Diode module	See item AF52	15D1, 15D2. 15D3, 15D3
AF7	2		IGBT module	Type GAL, see item AF50	15Q2, 15Q4
AF8	2		IGBT module	Type GAR, see item AF50	15Q1, 15Q3
-	1	0192 058 101	Thermal compound	For fitting of items AF4, AF5, AF6, AF7 and AF8	

* Special screw with built-in washer and spring washer function

Mig U5000i WeldCloud™, Mig 5000i WeldCloud™ 460 V

C = Component designation in the circuit diagram					
Item	Qty	Ordering no.	Denomination	Notes	C
BC1a	1	0458 312 001	Top box		
BC1b	1	0487 201 850	Circuit board	Configured for equipment ID 17 Replacing 0487 201 888	20AP1
BC1c	1	0458 313 001	Bottom box		
-	2		Screw	M5×8	
-	2		Screw	RXPT 8-16×12	
BC2	1	0458 881 001	Protection cap		
BC3	1	0458 681 884	Cable double burndy	Included in item BC18	XP2, XS30
BC4	2	0193 052 980	Screw		
BC5	1	0458 629 884	Cable set common	Connectors included: XP6, XS7, XS8, XS15, XS20, XS21, XS22, XS23, XS24, XS25, XS27, XS28	<-----
BC6	1	0458 314 001	Dust protection		
BC7	1	0394 516 038	Spacer screw	M5×30	
BC8	1	0486 855 884	Printed circuit board	Relay board, Replacing 0486 855 880	20AP2
-	1		Screw	M5×8	
-	1	0193 700 704	Ribbon cable	Included in item BC8. Connecting 20AP2 to 20AP1	20XS1
BC9	9		Connector	Included in item BC5	
BC10	1	0466 884 003	Connection		XP6
BC11	2		Socket	Included in item BC5	
BC13	1	0459 285 001	Fuse	4 AT	
BC14	1	0459 284 001	Fuse holder		
BC15	1	0456 806 001	Cover plate		
BC16	1	0458 709 002	Cover 2-hole	For Mig 5000i	
BC16	1	0458 709 003	Cover 3-hole	For Mig U5000i	
BC17	1	0458 629 885	Cable set	Connectors included: XS10, XS11, XS16, XS17, XS18, XS26, XS29, XS31	<-----
BC18	1	0458 679 881	Operating contact CAN doub.	Items BC3, BC18a, BC18b, BC18c, BC18d and BC18e included	AP1, C4
BC18a	1	0486 388 880	Circuit board	Connection board	AP1
BC19	2	0366 285 001	Dust cap		
BC20	1	0459 314 880	Terminal resistor	Termination resistor	
BC21	1	0192 230 105	Blind plug	Only for Mig 5000i	
BC22	1	0192 038 102	Flat pin connector	5.3 mm	

SPARE PARTS LIST

C = Component designation in the circuit diagram					
Item	Qty	Ordering no.	Denomination	Notes	C
BC23	1	0459 147 882	Cable set coarse		
BC24	3	0194 069 003	Rubber inlet	Grommet	
BC25	2	0458 074 001	Inlet		
BC26	2	0191 548 009	Flat pin connector	Ø 6.3×0.8	
BC27	1	0458 624 003	Connection rail		
-	2		Washer	Ø 22/10.5×2	
-	2		Screw	M10×16	
-	2		Screw	M8×16	
-	2		Nut	M8	
BC28	1	0459 125 001	Connection rail	For Mig 5000i	
BC28	1		Connection rail	See item DD12 and DD13 for Mig U5000i	
BC29	1		Power module	See items AE1 to AE49	
-	6		Screw	M6×16	
BC30	1	0486 892 882	Printed circuit board		
BC31	1		Mains module	See items BD1 to BD21	
-	6		Screw	M6×16	
BC32	1	0458 802 003	Front panel		
-	3		Washer	Ø 4.3×8	
-	7		Nut	M4	
BC33	1	0369 733 005	Lamp	Orange LED	D1
BC34	1	0369 733 010	Indicating lamp	White	HL1
BC35	1	0458 601 001	Switch		2QF1
-	2		Screw	FXS ST3.5×9.5	
BC36	1	0366 296 003	Knob		

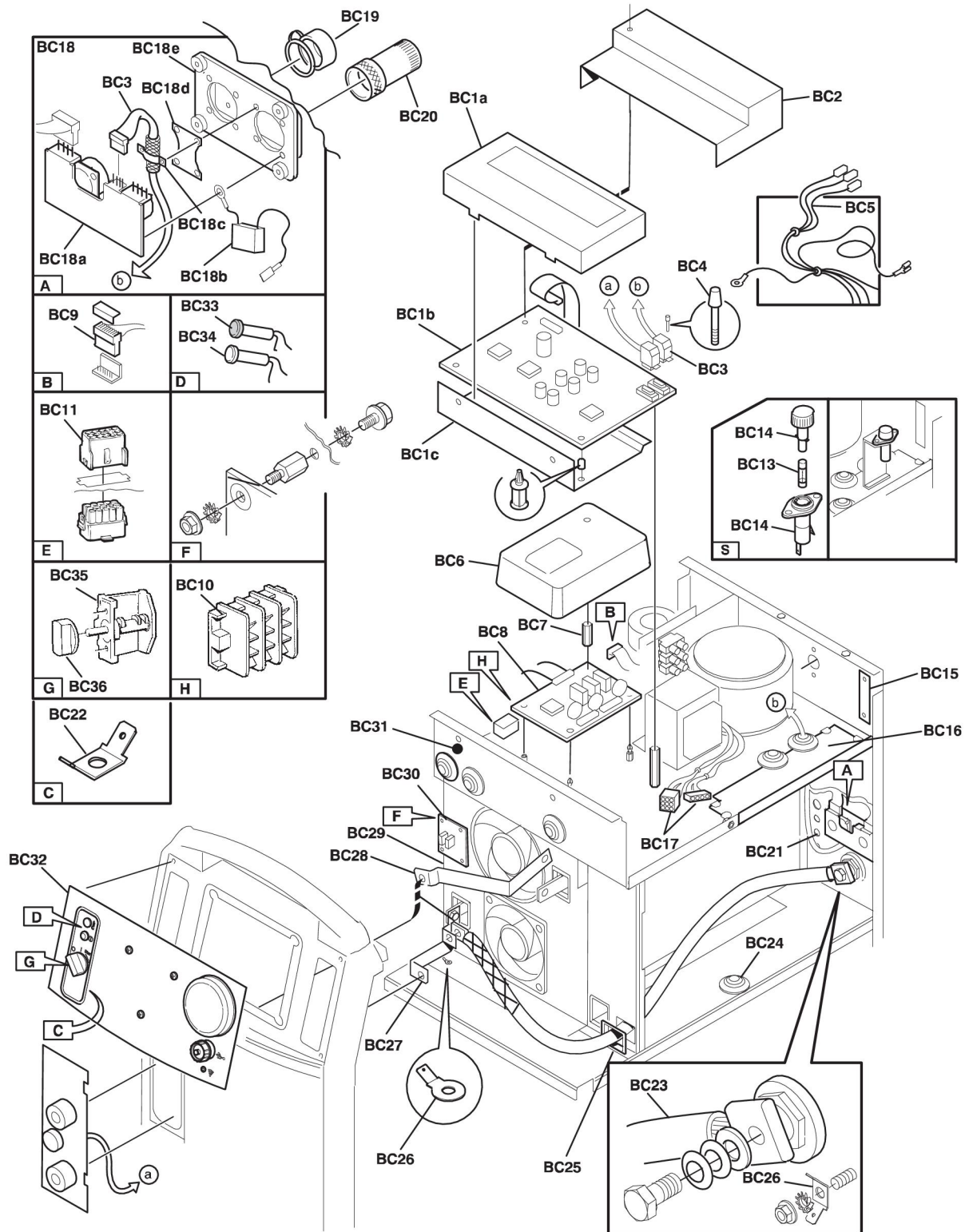

C = Component designation in the circuit diagram					
Item	Qty	Ordering no.	Denomination	Notes	C
1	1		Mig 5000i WeldCloud™ base		
2	1		WeldCloud™ box		
3	1		Mig 5000i base kit		
4	1	0445 429 002	Antenna (GSM, 3G, GPS & Wi-Fi)		

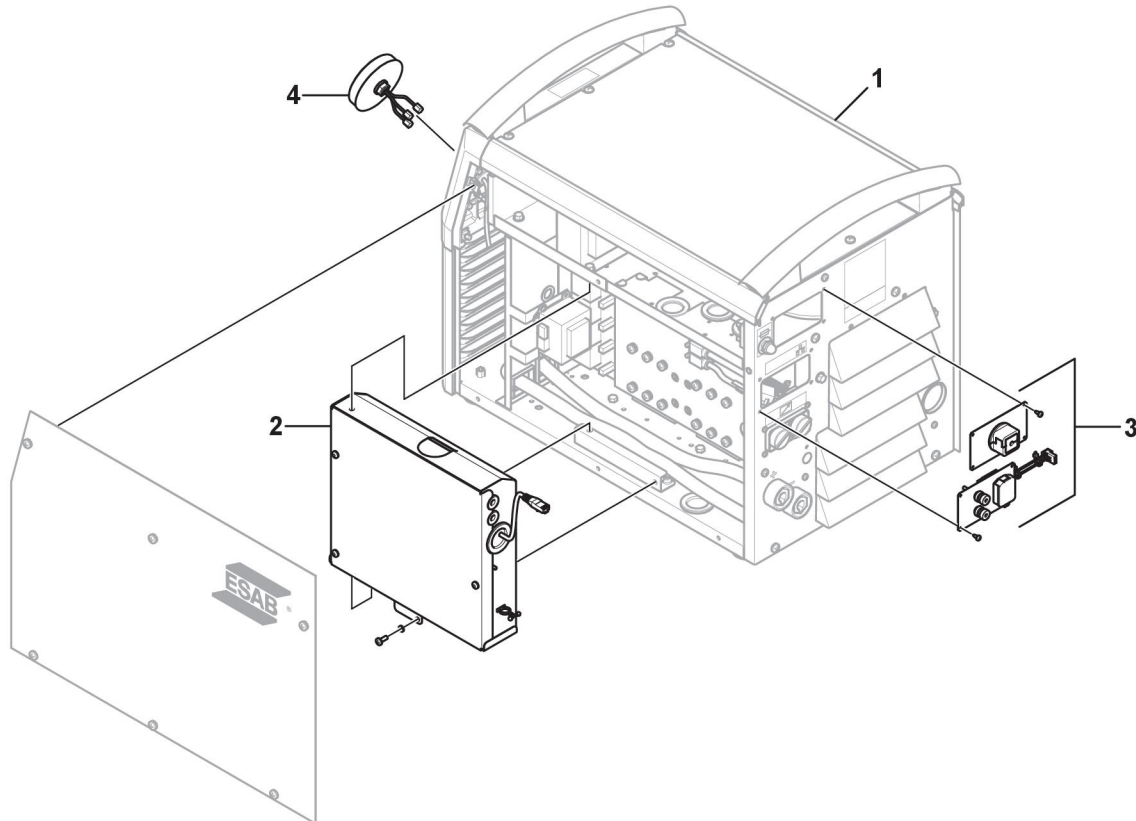

C = Component designation in the circuit diagram					
Item	Qty	Ordering no.	Denomination	Notes	C
1	1	0445 401 880	WeldCloud™ Box Base Assy		
2	1	0445 402 001	WeldCloud™ Box Cover		
3	1	0445 335 002	Antenna co-axial cable bracket		
4	1	0445 334 880	IPS		
6		0194 261 001	Double coated tape	2 × 0,08 m (26.2 ft)	
7	1	0487 679 884	Weld data unit	W82	
8	1	0445 325 002	SBC PCBA Type 2189		
11	1		Wi-Fi+BT Combo mini PCLe module	See item 100 below.	
12	1	0445 428 002	Mini PCle - 3G Module w/GPS		

SPARE PARTS LIST

C = Component designation in the circuit diagram					
Item	Qty	Ordering no.	Denomination	Notes	C
14	1	0445 337 001	Wi-Fi coax cable UFL-RPSMA Coaxial	For serial no. 803-, 950-, 608- 613-xxx-xxxx	
	1		Wi-Fi coax cable UFL-RPSMA Coaxial	From serial no. 834-xxx-xxxx. See item 100 below.	
15	2	0445 337 002	Wi-Fi coax cable		
16	8	0394 516 005	Spacer screw DSS M3×15		
17	4	0194 120 220	Screw MRT M3×6 FZB		
18	6	0219 501 305	Bricka AZ M3		
19	3	0394 516 017	Spacer screw DSS M4×8		
20					
21	3	0194 120 321	Screw MRT M5×6		
22	2	0455 122 002	Cable Holder		
23	2	0194 069 003	Grommet		
24	1	0465 806 001	Ethernet cable	PB-UTP-45-01	
25					
26	1	0462 017 001	Ethernet cable	RJ45 Cable	
27	1		Spacer	For robot interface board	
28	1		Spacer	For robot interface board	

Spare parts kits

Item	Ordering no.	Denomination	Notes
100	0445 424 882	Wi-Fi + Bluetooth kit	Includes items 11 and 14 (the new design from serial no. 834-xxx-xxxx)

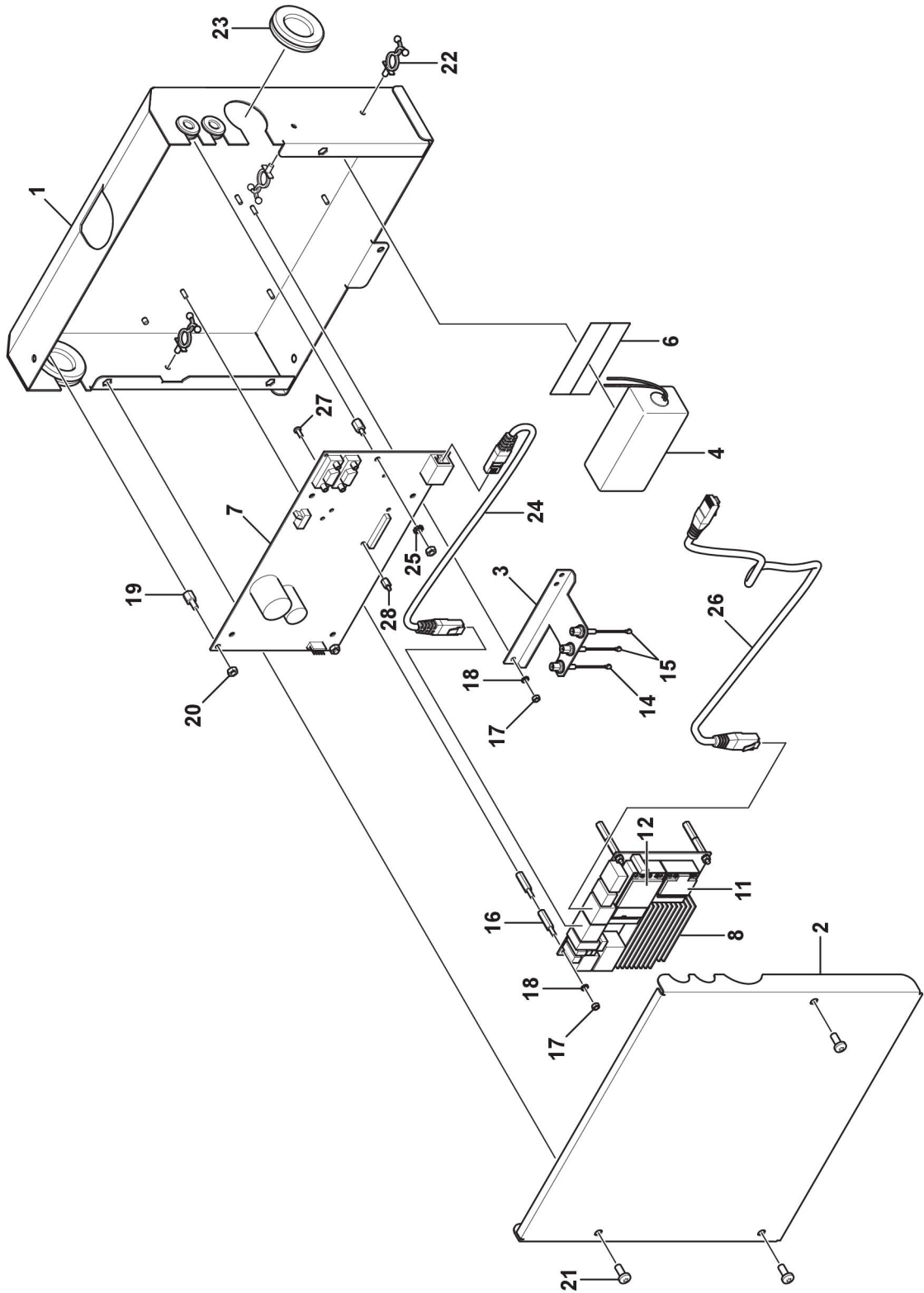

Spare parts sets

Item	Ordering number	Denomination	Notes
AF50	0458 920 880	IGBT modules set	Includes: item AF7 IGBT type GAL and item AF8 IGBT type GAR, one of each. Thermal compound, roller and mounting instruction
AF51	0458 920 881	Rectifier set	Includes: item AF5 rectifier bridge 15BR1, thermal compound, roller and mounting instruction
AF52	0458 920 882	Diode module set	Includes: diode module item AF6, thermal compound, roller and mounting instruction. Note: There is only one diode module in the set.
-	0458 910 002	Roller handle	For the roller in the spare parts sets above

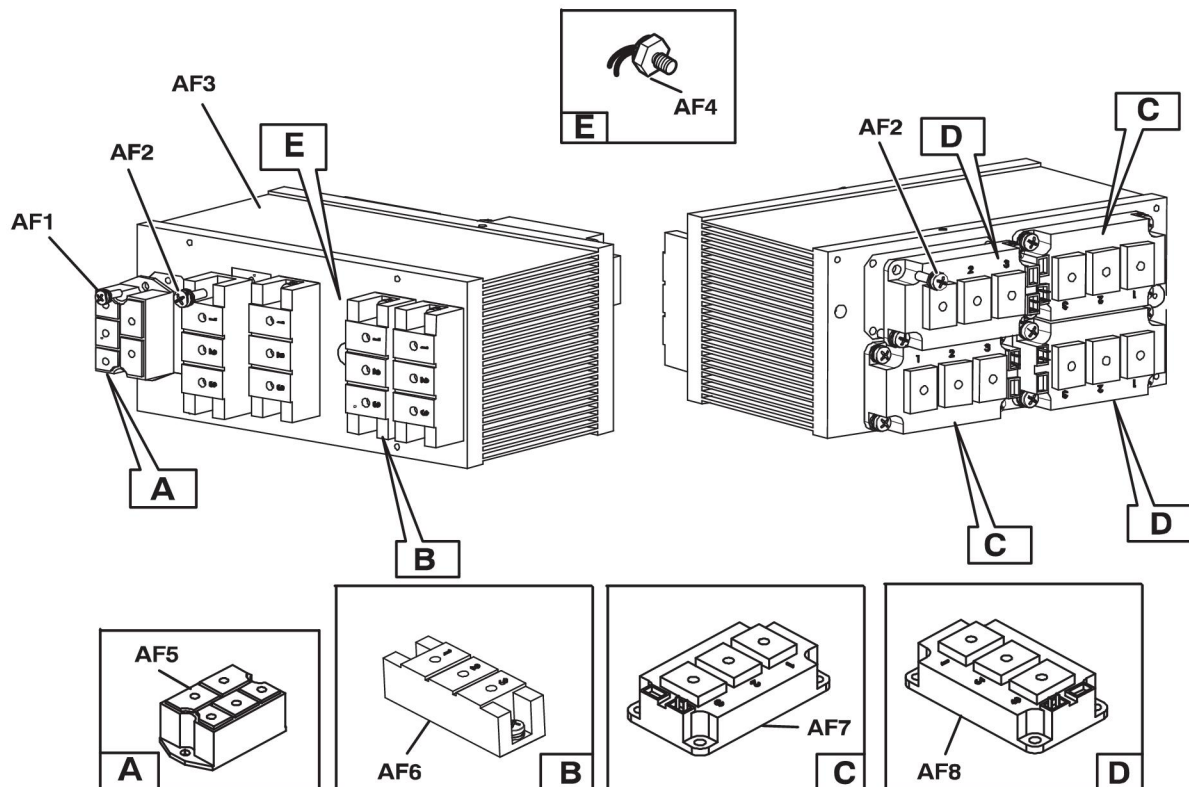

SPARE PARTS LIST

C = Component designation in the circuit diagram					
Item	Qty	Ordering no.	Denomination	Notes	C
BE1	1	0467 118 001	Waterflow switch	Option	5SL1
BE2	1	0467 864 007	Thermal switch	Closes at 45 °C (113 °F), opens at 35 °C (95 °F) Use thermal compound when mounting	5ST1
BE3	1	0458 745 881	Cable set	Connectors included	5XP17, 5XP18, 5XT1
BE4	4		Screw	M6x16	
BE5	1	0458 556 001	Fan plate		
BE6	4	0457 212 001	Clips		
BE7	1	0458 555 001	Fan holder		
BE8	1	0365 803 012	Quick connector	Female, blue	
BE9	1	0365 803 011	Quick connector	Female, red	
BE11	2	0457 987 001	Water hose	L = 0.68 m D = 17/10 mm To be ordered per metre	
BE12	1	0458 385 001	Bottom plate		
BE13	2	0458 558 001	T connection		
BE14a	1	0459 025 001	Hose	From red connector.	
BE14b	1	0457 987 002	Hose	To radiator. L = 0.075 m D = 17/10 mm To be ordered per metre	
BE14c	1	0457 496 001	Hose		
BE15	1	0458 370 880	Water outlet with lock	Complete, for details see items HF1 to HF14	5S1
BE16	16	0190 484 002	Hose clamp		
BE17a	1	0459 026 001	Hose	From blue connector.	
BE17b	1	0459 025 001	Hose	To pump.	
BE18	3	0455 122 002	Cable saddle	Assemb. hole 4 mm	
BE19	1	0458 560 001	Stop plate tank		
BE20	1	0369 827 001	Fan		5EV1
BE21	1	0469 692 002	Pump	Delivered with capacitor.	5M1
-	1		Capacitor	5 µF 450 V AC	5C2
BE23	2	0458 792 001	Hose		
BE24	1	0459 044 880	Tank with connections	Water tank	
BE24a	1	0457 245 002	Tank cap	Included in item BE24	
BE25	1	0458 559 001	Radiator		
BE26	1	0191 085 203	Capacitor	3 µF 400 V	5C1

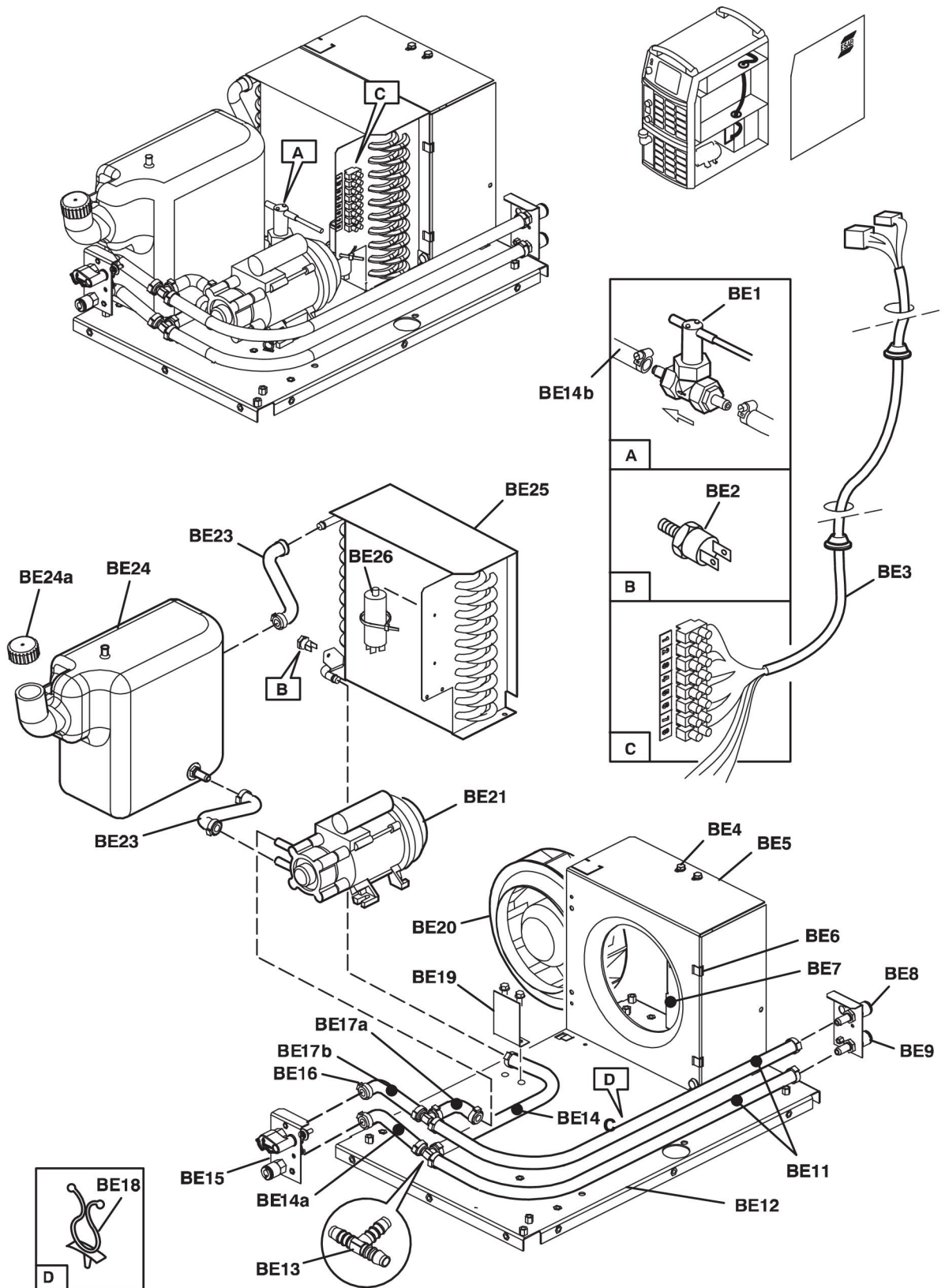

SPARE PARTS LIST

Item	Qty	Ordering no.	Denomination	Notes
HF1	1		Nut	M5
HF2	1		Washer	D16/5x1
HF3	1		Spring	
HF4	1		Water lock cam	
HF5	1	0365 803 009	Quick connector	Female, blue
HF6	1		Water lock bushing	
HF7	1		Water lock outlet	
HF8	1		Screw	M5x35
HF9	1		Nut	M3
HF10	1	0458 589 001	Insulation plate	
HF11	1	0458 364 001	Micro switch	
HF12	1	0365 803 008	Quick connector	Female, red
HF13	2		Screw	M3x20
HF14	2		Nut	M3
HF50	1	0458 370 900	Water connection spare kit	Contains items HF1, HF2, HF3, HF4, HF6, HF7 and HF8

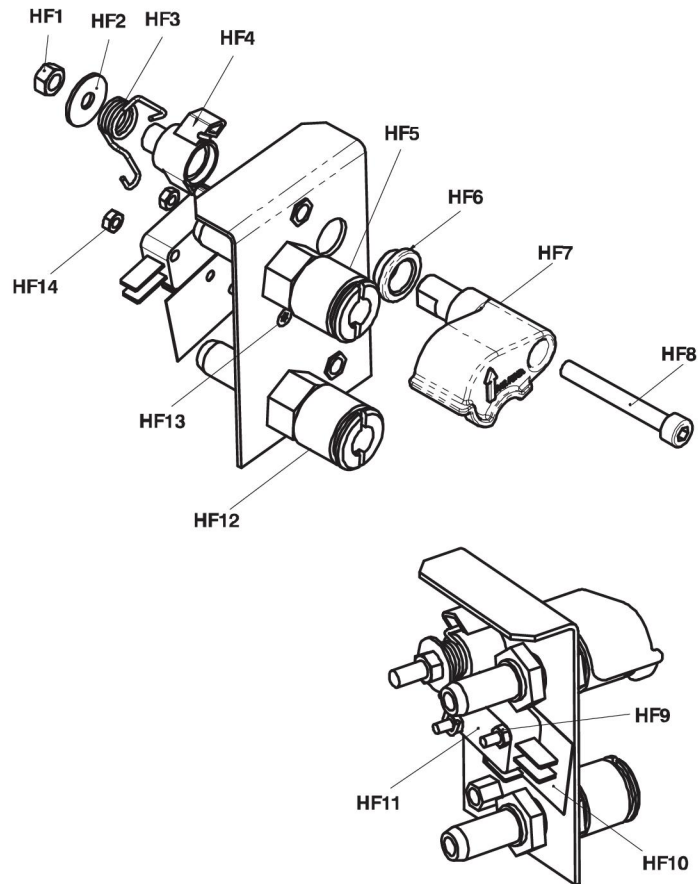



A WORLD OF PRODUCTS AND SOLUTIONS.



For contact information visit esab.com

ESAB AB, Lindholmsallén 9, Box 8004, 402 77 Gothenburg, Sweden, Phone +46 (0) 31 50 90 00

<http://manuals.esab.com>

